

# Emergency Inverter for Round Highbay



## FEATURES

- UL Listed for US and CANADA
- Listed to UL924 and tested to CSA C22.2 NO.141 Field or factory installation
- Low energy consumption CEC Title20 compliance
- High output voltage
- Constant output power
- Self-testing
- Battery: Over Temperature Protection  
Over Charge Protection  
Over Discharge Protection
- Remote test: Distance for 98ft (This function is optional)
- Built-in Integrated junction box
- For wiring to the led driver's input

## SPECIFICATIONS

- Input Voltage: 100~347Vac, 50/60Hz
- Input Current: 200mA max.
- Recharge Power: 12W
- Output Voltage: 170Vdc
- Emergency Power: 25W/40W
- Recharge Time: 24Hrs
- Discharge Time: 1.5H
- Warranty: 5 Years
- Vaux: 12Vdc  $\pm$  0.2A
- Battery: Li-ion
- Ambient Temp: 32~122°F (0~50°C)
- Weight: 3.96 lbs (1.8kg) max.
- Surge Protection: Line-Neutral 3KV

## SPECIFICATION CHART

Models	Emergency Power	Output Voltage
EMRHB-25170	25 Watts (Constant)	 <b>HIGH VOLTAGE OUTPUT</b> <b>170VDC</b>
EMRHB-40170	40 Watts (Constant)	

EMRHB-25170 is for 100, 150, 200W Round Highbay.  
 EMRHB-40170 is for 100, 150, 200, 240, and 300W Round Highbay

## SELF-TESTING

The integrated Self-Diagnostic circuitry will automatically conduct monthly 30-second and annual 90-minute tests to verify proper emergency capability per Life Safety Code requirements. NFPA 101, Life Safety Code Outlines the following schedule:

- **Monthly**- During AC mode, the system conducts a (30)seconds self-discharge test of the emergency led driver every 30 days. And automatically restore to normal charging after (30)seconds dis-charged.
- **Annually**- During AC mode, the system conducts a (90)minutes self-discharge test of the emergency led driver every 365 days. And automatically restore to normal charging after fully dis-charged.

# Emergency Inverter for Round Highbay

## DIMENSIONS

SIZE : L6.8"(173mm)\*H5.47"(139mm)

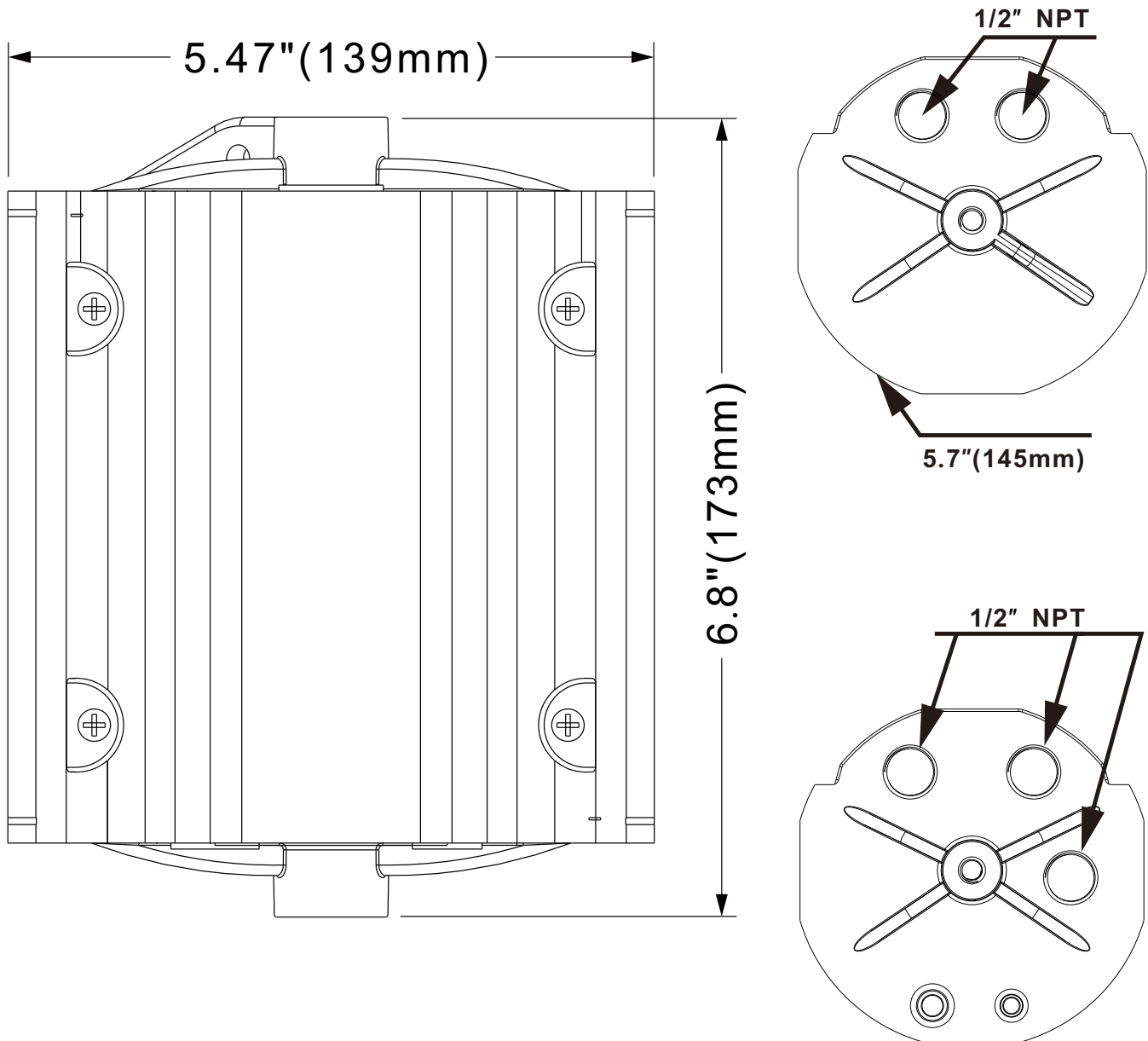

## ACCESSORIES

 <p><b>A</b></p>	 <p><b>B</b></p>	 <p><b>C</b></p>	 <p><b>D</b></p>	 <p><b>E</b></p>
<p>( 9 ) pcs of Wire nuts</p>	<p>( 1 ) pc of Safety rope</p>	<p>( 1 ) pc M10 Hanging Hook Bolt            ( 1 ) pc M10 Hanging Ring Bolt</p>	<p>( 1 ) pc of Remote  <b>( Optional )</b></p>	<p>( 1 ) pcs Connector Suitable for wire diameter 0.118-0.248" (3-6.3mm)            ( 2 ) pcs Connector Suitable for wire diameter 0.196-0.393" (5-10mm)</p>

# EMRHB SERIES INSTALLATION MANUAL

**!!! IMPORTANT SAFEGUARDS !!!**

**WHEN USING ELECTRICAL EQUIPMENT, BASIC SAFETY PRECAUTION SHOULD ALWAYS BE FOLLOWED, INCLUDING THE FOLLOWING**

## READ AND FOLLOW ALL SAFETY INSTRUCTION

1. **CAUTION-** This emergency driver provides more than one power supply output source. To reduce the risk of electrical shock, disconnect both normal and emergency source by turning off the A.C. branch circuit.
2. **CAUTION-** Servicing of this equipment should be performed by qualified personnel only.
3. **CAUTION-** Do not attempt to service the battery. A sealed, no-maintenance battery is used that is not field replaceable. Replace the entire unit when necessary.
4. **CAUTION-** The use of accessory equipment not recommended by the manufacturer may cause an unsafe condition, void warranty, and result in non-compliance with UL specifications.
5. **CAUTION-** The emergency driver requires an un-switched AC power source of **100-347VAC**, 50/60Hz. Installer must confirm that fixtures input voltage covered 120VAC before installation. It will supply power under an output voltage of 170VDC in emergency mode for at least 90 minutes.
6. **CAUTION-** Battery pack should be charged for 24 hours every 6 months during storage.
7. Battery in this unit may not be fully charged. After electricity is connected to the unit for at least 24 hours, then normal operation of this unit should take effect.
8. For use in 0°C minimum, 50°C maximum ambient temperatures. Suitable for use in wet locations and plenum spaces.
9. The emergency driver should be mounted in locations and at heights where it will not readily be subjected to tampering by unauthorized personnel.
10. Do not use this equipment for anything other than its intended use. Equipment only use for LED Lighting emergency backup.
11. Do not mount near gas or electric heaters. Do not let power supply cords touch hot surfaces.
12. Do not make or leave any other open holes in the wiring enclosure or electrical component enclosure during installation.
13. This fixture is for use with grounded, UL Listed, this model can use in wet location. Not for use in heated air outlets or hazardous locations.
14. The emergency driver have battery inside, forbidden for insulation voltage(I/P-O/P) test.
15. Equipment should be mounted in locations and at heights where it will not be subjected to tampering by unauthorized personnel.
16. The equipment is intended for ordinary locations and for permanent installation into one or more Listed emergency luminaires.
17. Suitable for minimum 10W LED lamp.
18. Maximum installation height: 28.5 feet.

## LUMEN OUTPUT DURING EMERGENCY OPERATION

The luminaire rated data and maximum mounting height can be found as follows:

1. Determine the fixture efficacy under normal AC operation, based on fixture manufacturer published data in lumens per watt(LM/W).
2. Reference DLC QPL ([www.designlights.org](http://www.designlights.org)) and Energy Star QPL ([www.energystar.gov](http://www.energystar.gov)) for rated data on fixture efficacy.

If fixture is not found on DLC or Energy Star Qualified Product List, contact fixture manufacturer.

3. Multiply **fixture LM/W by rated output power of emergency pack** Example 'model EMRHB-25170' is **25 W**  $\times$  **100 LM/W** = **2500 Lumens**

This product has been designed and tested to compatible with most of led drivers in the market. However, compatibility cannot be guaranteed with all current and future LED drivers or fixtures. So compatibility testing of the end-use system is suggested. Please contact the factory with any questions.



**Caution: Before Installation, Make Certain The A.C. Power is Off !**

### STEP 1: ASSEMBLING NOTICE

- > Select a suitable location on the hangable device.
- > The Maximum weight of lighting fixture should be less than 20kg.
- > Turn off the AC power before installing.
- > Assembling the emergency LED driver with the Safety Rope with the chain link connector.
- > Please use waterproof connectors in position AC input wire interface and Dimming wire interface for application in wet location.

### STEP 2: INSTALLING

- > Install the ring M10 Hanging Ring Bolt to the emergency LED driver and fix it with screw.
- > Install the M10 Hanging Hook Bolt to the emergency LED driver and fix it with screw.
- > Install the UFO high bay to the Hanging Hook of emergency LED driver and tighten the screws.

### STEP 3: WIRING

- > Before wiring, make sure safety rope is securely locked and make sure all the screws are tight.
- > Open the cover of junction box.
- > Select the appropriate wiring diagram to connect the emergency LED driver to the AC driver. For other diagrams, consult the manufacturer.
- > The voltage input to the dimmable wires (DIM+, DIM-) of emergency LED driver must less than 20Vdc.
- > Using wire nuts to cover un-used wires and make sure all connections are in accordance with the NEC and any local regulations.

### STEP 4: TESTING

- > After wiring is complete, apply A.C. power. Check if the indicator light lights or not, which will indicate the battery's charging situation.
- > The battery in this unit may not be fully charged. A short-term discharge test may be conducted after the emergency LED driver has been charging for 1 hour. Charge for 24 hours before conducting a long-term discharge test.

**SAVE THESE INSTRUCTIONS**



THIS PRODUCT CONTAINS A RECHARGEABLE LITHIUM-ION BATTERY. THE BATTERY MUST BE RECYCLED OR DISPOSED OF PROPERLY TO PREVENT FIRE.

# Emergency Inverter for Round Highbay

## INSTALLATION INSTRUCTIONS

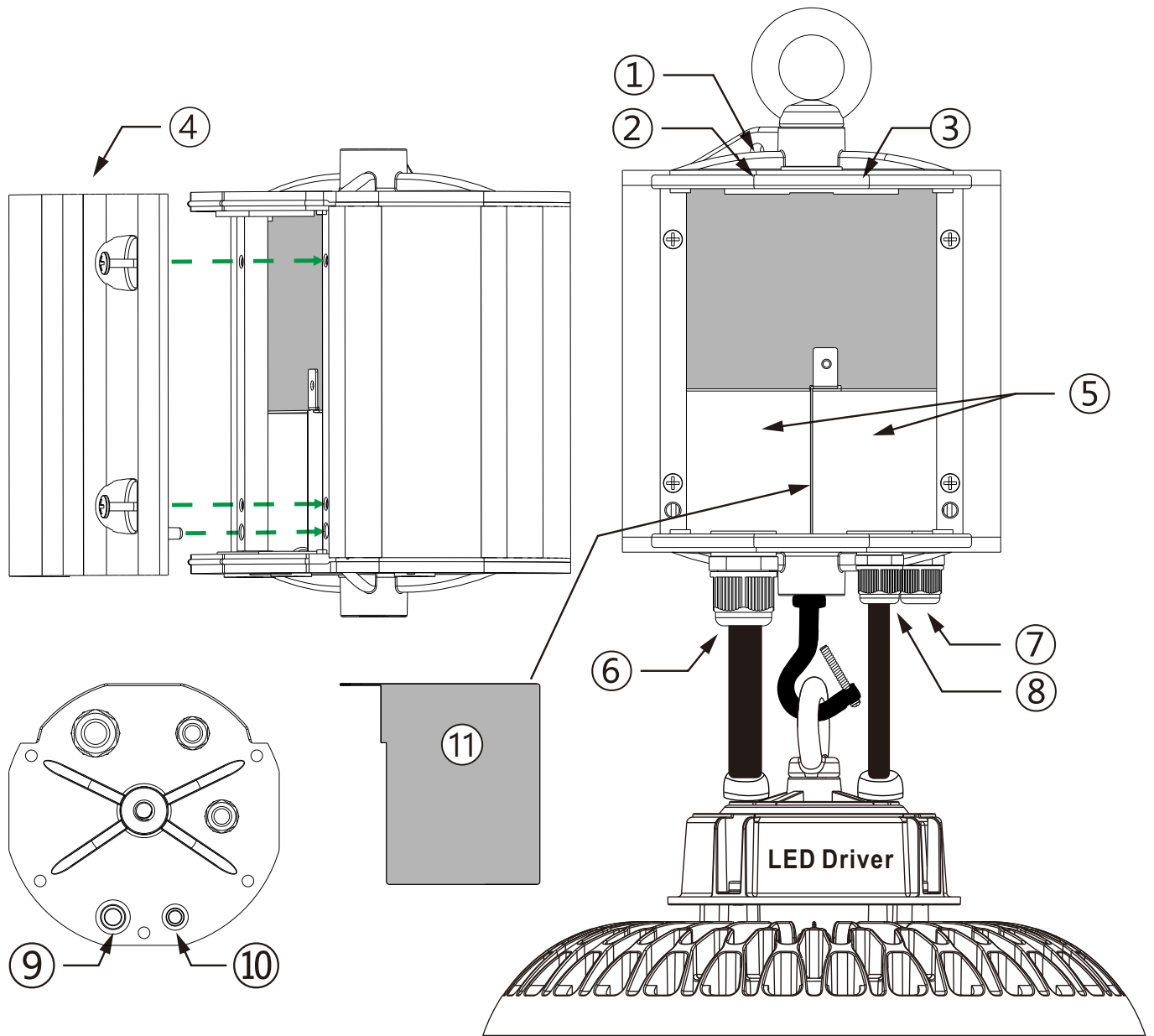

① Safety rope interface	⑥ LED Driver input wire
② AC input wire interface	⑦ Sensor wire interface
③ Dimming wire interface	⑧ LED Driver dimming wire
④ Integrated junction box cover	⑨ Charge Indicator & Test switch
⑤ Junction box	⑩ Signal receiver
⑪ Septum	

# Emergency Inverter for Round Highbay

## WIRING DIAGRAM

**Note:** The LED fixture must be integrated with 0-10V driver, when LED fixture power is more than Emergency LED driver unit power.

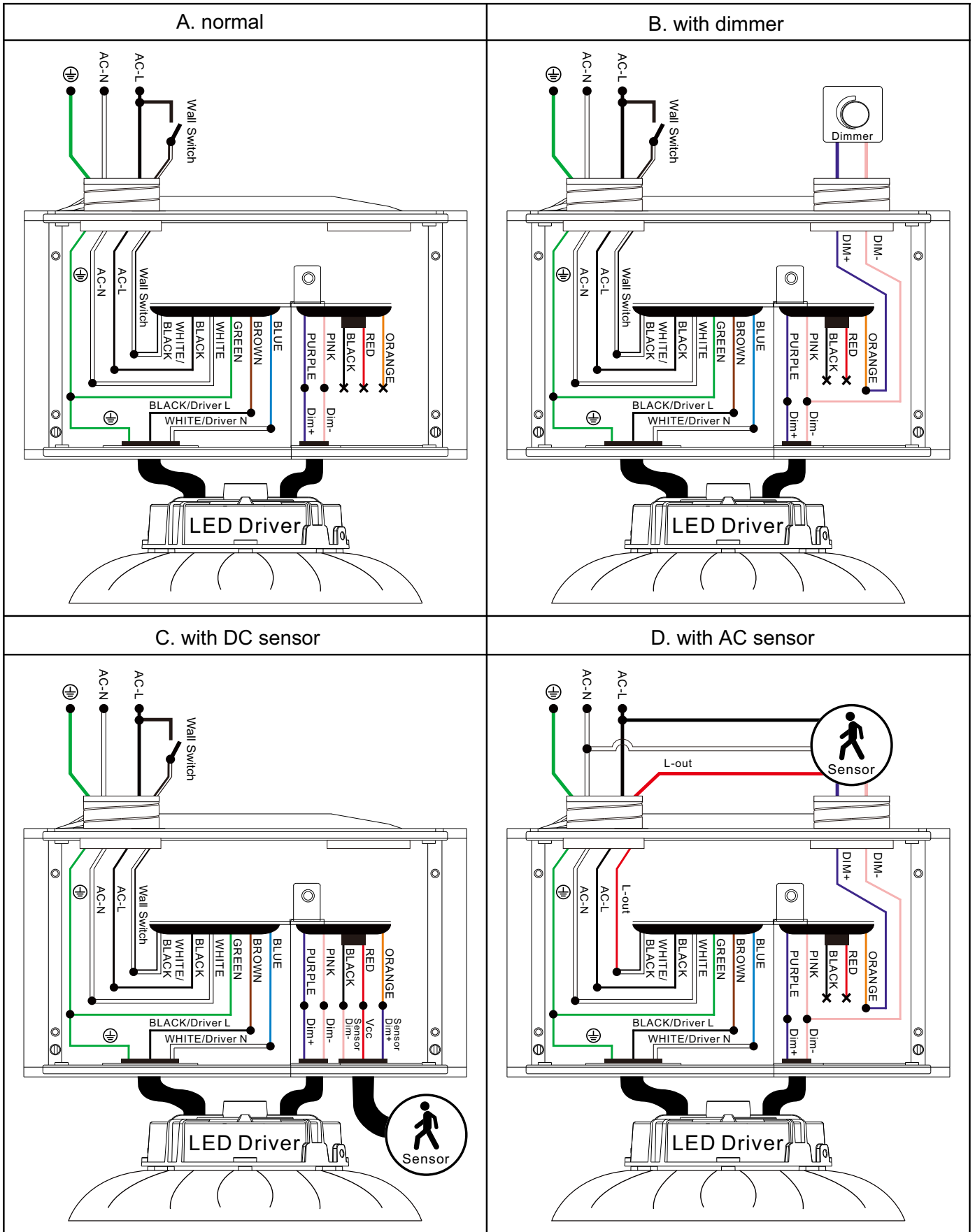

# Emergency Inverter for Round Highbay

## OPERATION(INDICATOR STATUS)

Mode	Test Switch Operation	Wireless Remote Operation	Indicator Status	Comment & Solutions
AC MODE (1)	NO Press	NO Press	ON(no flashing)	Emergency led driver is charging
AC MODE (2)	Press once	Press Button A once	2s ON and 2s OFF (slow flashing)	Emergency led driver is conducting a 30s short-term emergency test,After 30 seconds,it will automatically restore to normal charging mode
AC MODE (3)	Press twice (2s) in sequence	Press Button B once	2s ON and 2s OFF (slow flashing)	Emergency led driver is conducting a long-term emergency test until battery is fully discharged
EMERGENCY MODE	NO Press	NO Press	2s ON and 2s OFF (slow flashing)	Emergency led driver is conducting a long-term emergency test until battery is no power

ABNORMAL	When flashes (50ms) ON and (50ms) OFF fast or goes off, the Emergency led driver pack is abnormal. Contact the manufacturer.			
----------	--	--	--	--

<b>WARNING</b> Risk of Electric Shock 	<b>Note:</b> Please press once test switch to make certain the battery is turned off, before installation, maintenance, storage or shipping.
--	--

## PACKAGE

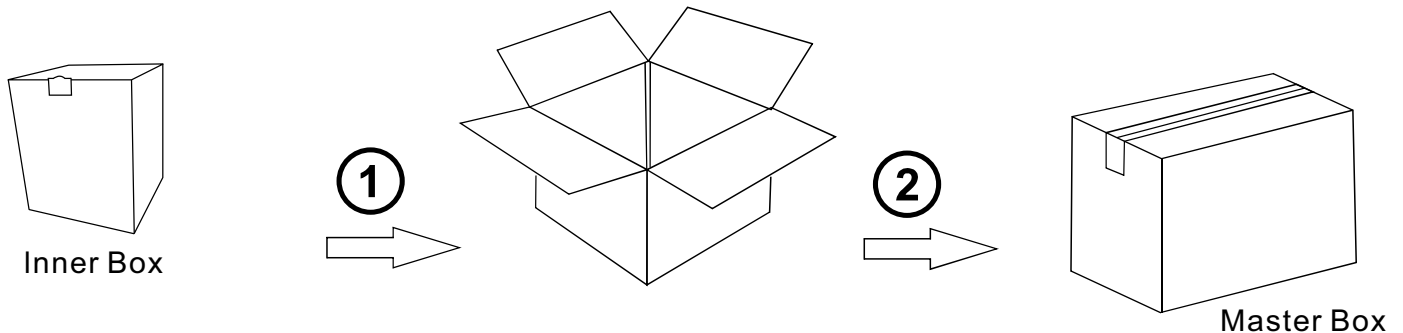

## PACKAGE INFORMATION

Power	Length	Width	Height	G.W(kg)	N.W(kg)	QTY(pcs)
25W	14.96"(380mm)	14.96"(380mm)	9.84"(250mm)	9.6	6.8	4
40W	14.96"(380mm)	14.96"(380mm)	9.84"(250mm)	10	7.2	4